

# Sirengo 15D

LONG RANGE SIREN **CE**  

An outdoor weatherproof industrial siren made with a durable aluminium body and powerful continuous rated electric motor, available in 3 phase voltage. The very powerful low frequency sound output ensures a sound distance of up to 15km. This is our largest siren in the Sirengo motorised siren range.

A reliable siren with a 2-year guarantee\*

### Typical applications:

Emergency and warning notification device at open cast mines, quarries, larger factories, and open areas like golf courses, airports, harbours, and prisons. Suitable for use as an emergency and warning notification device at indoor noisy environments.



## SPECIFICATIONS

VOLTAGE	380V AC (3Φ)   525V AC (3Φ)
DUTY CYCLE	Continuous Rated
SOUND OUTPUT	145dB(A) at 1m
SOUND FREQUENCY	480Hz / 560Hz
APP. RANGE	15 000m in still air on open field
MOTOR	7.5kW motor - 2875rpm
CURRENT CONSUMPTION	380Vac - 5A   525Vac - 3A
IP RATING	IP 55 (IP 65 or IP 56 available on request)
WEIGHT	120kg
PACKING DIMENSIONS	600mm x 650mm x 750mm
NOTES	

## PRODUCT CODES

<b>Code</b>	SML1538	SML1552							
<b>Detail</b>	380V	525V							

## TECHNICAL DRAWINGS

All dimensions in mm

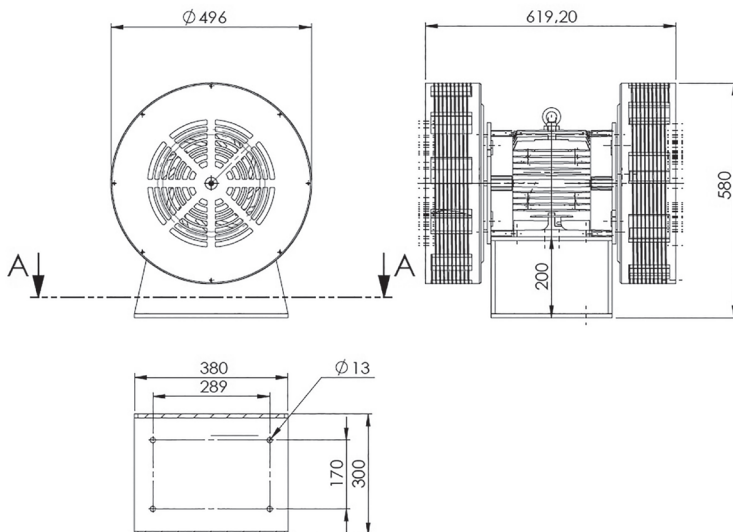

## OPTIONAL EXTRAS

SHUTTER VALVE

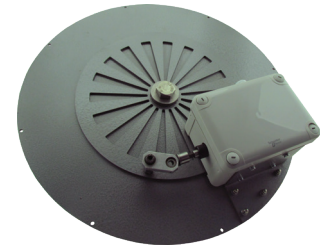

ANTI-ICING UNIT

