

An outdoor weatherproof industrial siren made with a durable aluminium body and powerful continuous rated electric motor. The low frequency sound output ensures a sound distance of up to 1500m.

A reliable siren with a 2-year guarantee\*

**Typical applications:**

Emergency and warning notification device at open cast mines, quarries, larger factories, and open areas. Suitable for use as an emergency and warning notification device at indoor noisy environments.

LONG RANGE SIREN   

# Sirenco 1500S

## SPECIFICATIONS

VOLTAGE	110VAC/DC   220VAC/DC
DUTY CYCLE	Continuous Rated
SOUND OUTPUT	125dB(A) at 1m
SOUND FREQUENCY	660Hz
APP. RANGE	1 500m in still air on open field
MOTOR	215W @ 6500rpm
CURRENT CONSUMPTION	110V - 1.0A   220V - 0.7A
IP RATING	IP 65
WEIGHT	6.6kg
PACKING DIMENSIONS	240mm x 183mm x 183mm

NOTES | Unit is also available in a Vertical configuration.

## PRODUCT CODES

Code	SM15110	SM15220		SM1511V	SM1522V				
Detail	Normal	110V	220V	Vertical	110V	220V			

## TECHNICAL DRAWINGS

All dimensions in mm

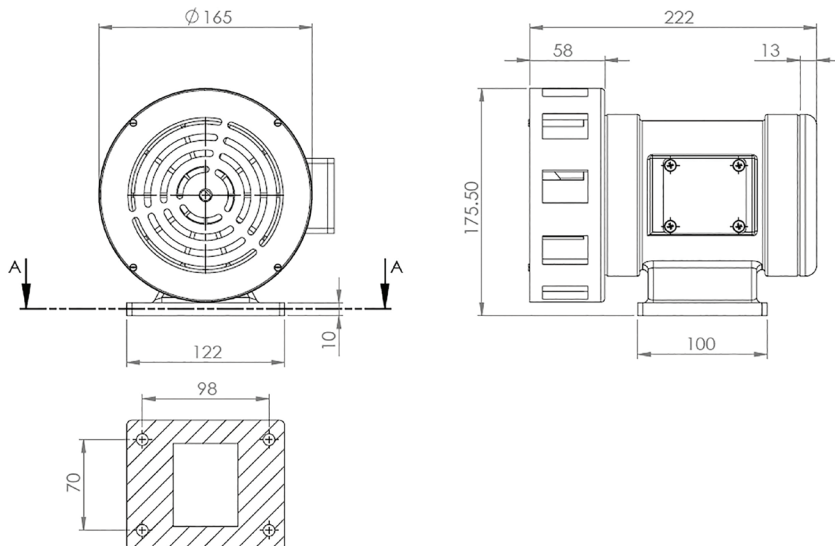

## OPTIONAL EXTRAS

Sirenco 1500S Vertical



School & Factory Timer

