

An outdoor weatherproof industrial siren made with a durable aluminium body and powerful continuous rated electric motor, available in both single and 3 phase voltages. The very powerful low frequency sound output ensures a sound distance of up to 3km.

A reliable siren with a 2-year guarantee*

Typical applications:

Emergency and warning notification device at open cast mines, quarries, large factories, and open areas like golf courses, harbours, and prisons. Suitable for use as an emergency and warning notification device at indoor noisy environments.

LONG RANGE SIREN   

Sirencos 3LF

SPECIFICATIONS

VOLTAGE	220VAC 380VAC(3Φ) 525VAC(3Φ)
DUTY CYCLE	Continuous Rated
SOUND OUTPUT	125dB(A) at 1m
SOUND FREQUENCY	560Hz
APP. RANGE	3 000m in still air on open field
MOTOR	1.1 kW @ 3000rpm
CURRENT CONSUMPTION	220V AC - 9A 380V AC(3Φ) - 5A 525V AC(3Φ) - 2A
IP RATING	IP 55 (IP 65 or IP 56 available on request)
WEIGHT	22kg
PACKING DIMENSIONS	400mm x 380mm x 300mm

NOTES | Unit is also available in a Vertical configuration.

PRODUCT CODES

Code	SM3LF22	SM30380	SM30525		SM3LV22	SM3LV38	SM3LV52	
Detail	Normal	220V	380V	525V	Vertical	220V	380V	525V

TECHNICAL DRAWINGS

All dimensions in mm

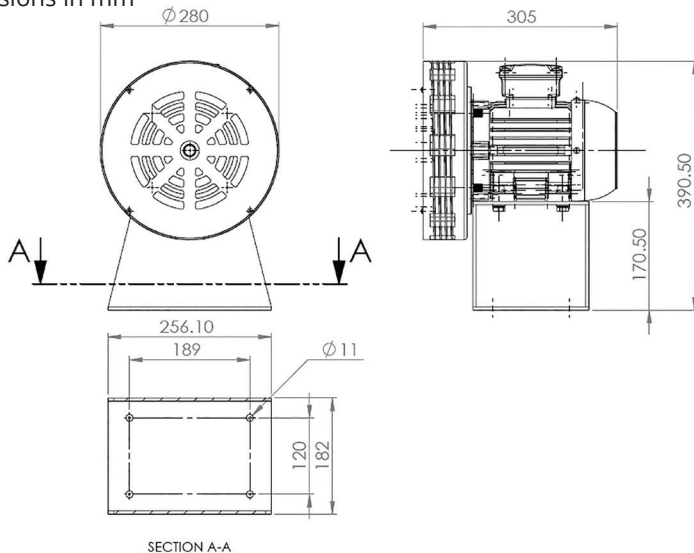

OPTIONAL EXTRAS

Sirencos 3LFV (Vertical)

