

Product SPECIFICATION SHEET



Jexi C800M, 1000M



Application

Clean water and liquids without particulate matter and aggressive chemicals, for filling tanks, water transfer, booster pump for homes with hydropneumatic system with On/Off pressure Control for automation operation

Materials

Pump body	Stainless Steel
Motor Bracket:	Cast Iron
Impeller:	Stainless Steel
Mechanical Seal:	Ceramic & Graphite
Motor Shaft:	Stainless Steel

Motor	Asynchronous 2 pole induction motor
Insulation:	Class B
Protection:	IPX4
Single phase with capacitor and built-in thermal protection	

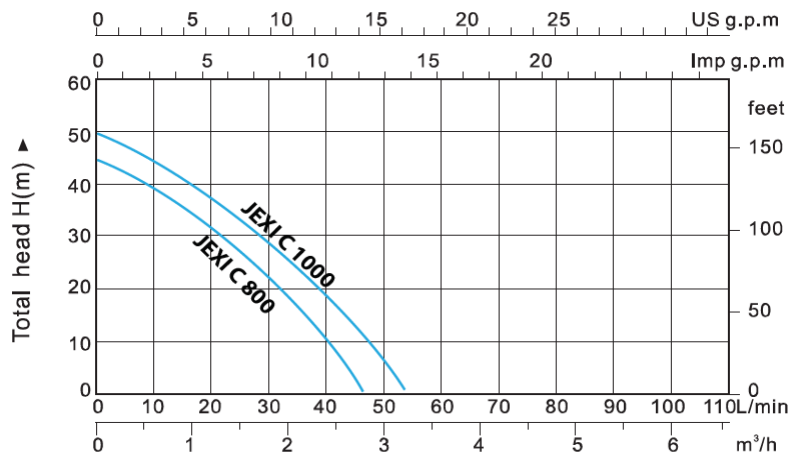

Code	Voltage	Power		Amps	Max Head (m)	Max Flow (l/min)	In / Out (Inch)
		KW	HP				
JEXI C800M	230VAC	0,6	0,8	4,2	45	46	1 x 1
JEXI C1000M	230VAC	0,75	1	5,1	50	52	1 x 1

BRANCH CONTACT DETAILS
 Johannesburg 010 202 3300
 Germiston 011 418 9600
 Cape Town 021 510 0710
 Pinetown 031 700 4215
 Riverhorse 031 492 4800

NATIONAL CALL CENTRE
 Sales 010 202 3400
 Technical 010 202 3500
www.acdc.co.za

Product SPECIFICATION SHEET

ACDC
DYNAMICS
www.acdc.co.za

Jexi C Series

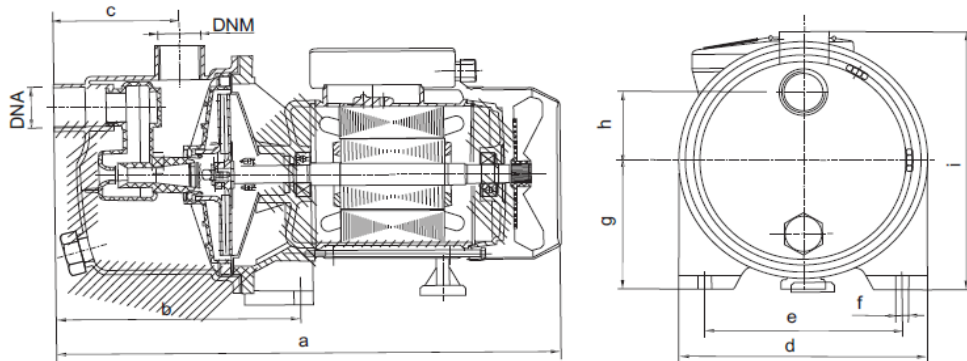

Model	DIMENSIONS (mm)										
	DNA	DNM	a	b	c	d	e	f	g	h	i
JEXI800M	1"	1"	380	190	95	198	148	8	105	56	208
JEXI1000M	1"	1"	380	190	95	198	148	8	105	56	208

BRANCH CONTACT DETAILS

Johannesburg 010 202 3300
Germiston 011 418 9600
Cape Town 021 510 0710
Pinetown 031 700 4215
Riverhorse 031 492 4800

NATIONAL CALL CENTRE

Sales 010 202 3400
Technical 010 202 3500

www.acdc.co.za